

OctaLIU

Eight-Channel E1/T1/J1 Line Interface Unit
PEF 22508 E



THE OctaLIU is the latest addition to Infineon's family of sophisticated E1/T1/J1 components. Designed to support both long haul and short haul applications, the eight-channel OctaLIU provides support for all standard E1/T1/J1 Line Interface Unit functions.

AS AN EIGHT-CHANNEL LIU, the OctaLIU is ideally suited to high channel-count applications that do not require E1/T1/J1 framing, or require framing and LIU functions to be in separate devices, such as M13 multiplexers, wireless base stations and routers.

USING INFINEON'S EASY 22508 Reference Design System, system vendors can quickly develop OctaLIU-based applications.

Applications

- M13 multiplexers
- Wireless base stations
- Routers
- Voice over packet gateways
- ATM and Frame Relay gateways
- Multi-service Access Platforms
- Digital Loop Carriers
- Digital cross connects
- Switches
- Remote access servers/concentrators
- SONET/SDH Add/Drop Multiplexers
- CSU/DSU equipment

Features

- Eight independent E1/T1/J1 long haul/short haul LIUs
- Software programmable T1/E1/J1 for a single BOM for all applications
- Integrated analog switch for impedance matching or protection switching
- Crystal-less wander and jitter attenuation/compensation according to:
 - TR 62411
 - ETS-TBR 12/13

- Clock generation unit accepts any reference clock from 1.02 MHz to 20 MHz
- Programmable transmit pulse shape for standard and flexible pulse generation
- Supports automatic protection switching
- Integrated line termination tuning by additional analog switch
- Receiver sensitivity exceeds -36 dB at 772 kHz, and -43 dB at 1024 kHz
- Rx and Tx line monitoring
- Versatile channel configurations
- Dual or single rail digital input and output to the framer interface
- Programmable in-band loop code according to TR62411
- Programmable elastic store for Rx and Tx clock wander and jitter compensation with controlled slip capability and slip indication
- PRBS generation and monitoring
- Detects and generates LOS and AIS alarms

General Features

- Meets Japanese standards including JT G.703, 704, 706, I.431
- Intel® or Motorola® type 8/16-bit microcontroller interface
- Serial SPI bus and serial SCI bus
- Low power consumption (100 mW per channel)
- Dual voltage 1.8 V/3.3 V power supply
- 17x17 mm PG-LBGA-256 package with 1.0 mm ball pitch
- Operating range from -40°C to 85°C

www.infineon.com/products

Wireline Communications



Never stop thinking.

Block Diagram OctaLIU

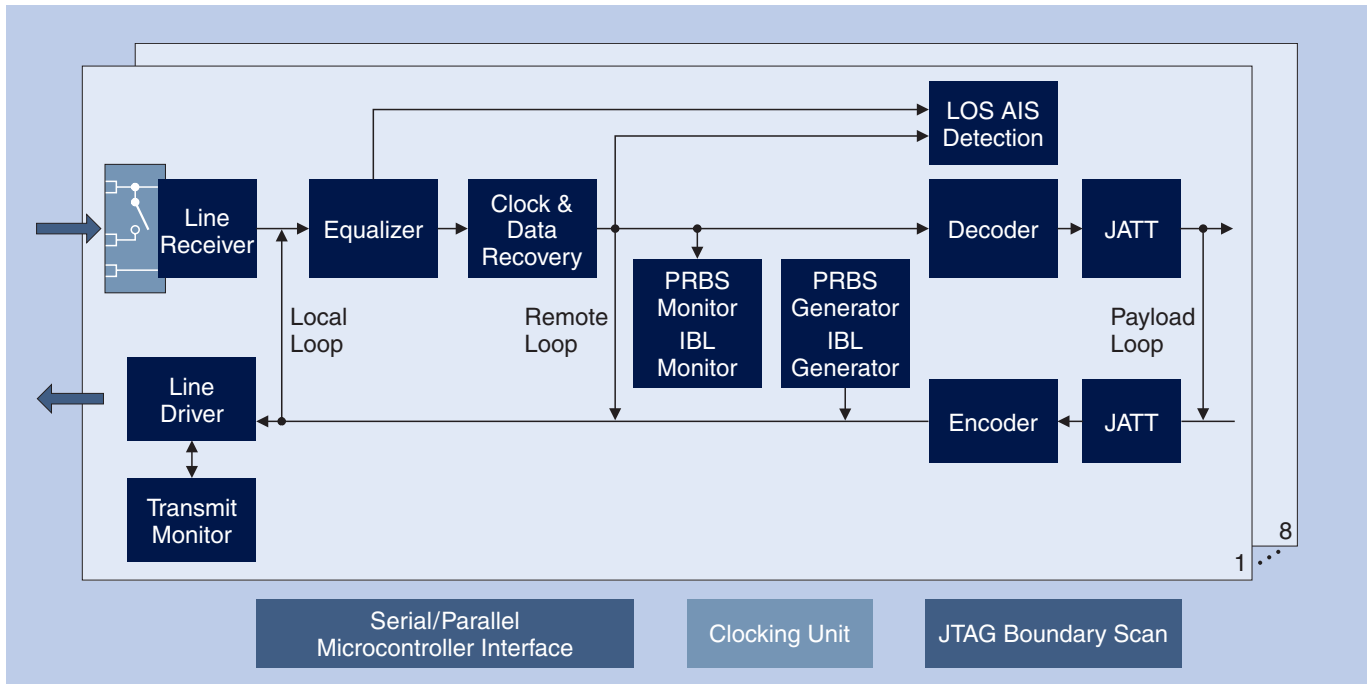

Ordering Information

OctaLIU IC

Product Sales Code	Description	Package
PEF 22508 E	OctaLIU Eight-Channel E1/T1/J1 Line Interface Unit	PG-LBGA-256

OctaLIU Reference Design System

Product Sales Code	Description	Package
EASY 22508	OctaLIU Reference Design System	One board, software, and documentation

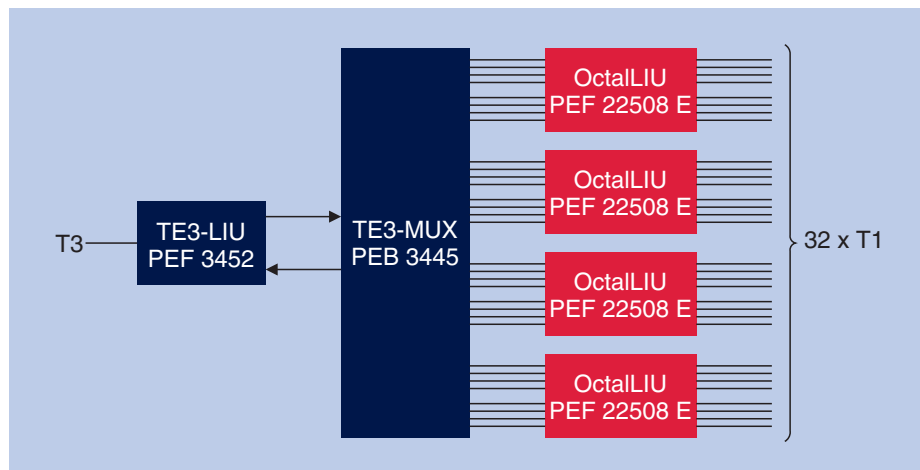

Application Example 32-Channel E1/T1/J1 Line Card with OctaLIU

How to reach us:

<http://www.infineon.com>

Published by
Infineon Technologies AG
St.-Martin-Strasse 53
81669 München

© Infineon Technologies AG 2004.
All Rights Reserved.

Template: pb_tmplt.fm/4

Attention please!

The information herein is given to describe certain components and shall not be considered as a guarantee of characteristics. Terms of delivery and rights to technical change reserved.

We hereby disclaim any and all warranties, including but not limited to warranties of non-infringement, regarding circuits, descriptions and charts stated herein.

Information

For further information on technology, delivery terms and conditions and prices please contact your nearest Infineon Technologies Office.

Warnings

Due to technical requirements components may contain dangerous substances. For information on the types in question please contact your nearest Infineon Technologies Office.

Infineon Technologies Components may only be used in life-support devices or systems with the express written approval of Infineon Technologies, if a failure of such components can reasonably be expected to cause the failure of that life-support device or system, or to affect the safety or effectiveness of that device or system. Life support devices or systems are intended to be implanted in the human body, or to support and/or maintain and sustain and/or protect human life. If they fail, it is reasonable to assume that the health of the user or other persons may be endangered.

Ordering No. B115-H8499-X-X-7600
Printed in Germany
PS 1004.5 nb